

PLAN OF LOT
DESCRIBED AS BEING PART OF LOT 158 ON SP219251

Metes and Bounds description of the area of land being on the Plan of Proposed Lot Reconfiguration prepared by Cottrell Cameron & Steen Surveys Pty Ltd referred to as Drawing Number 3549-2-SK1 dated 21 February 2013 which was approved by Redland City Council on 17 February 2014, described as Lot 158 on SP219251, Parish of Redland, County of Stanley and situated at 41 Bankswood Drive, Redland Bay

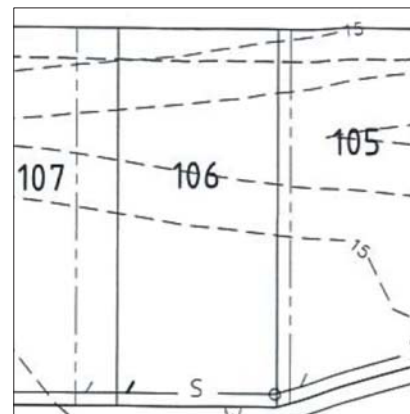
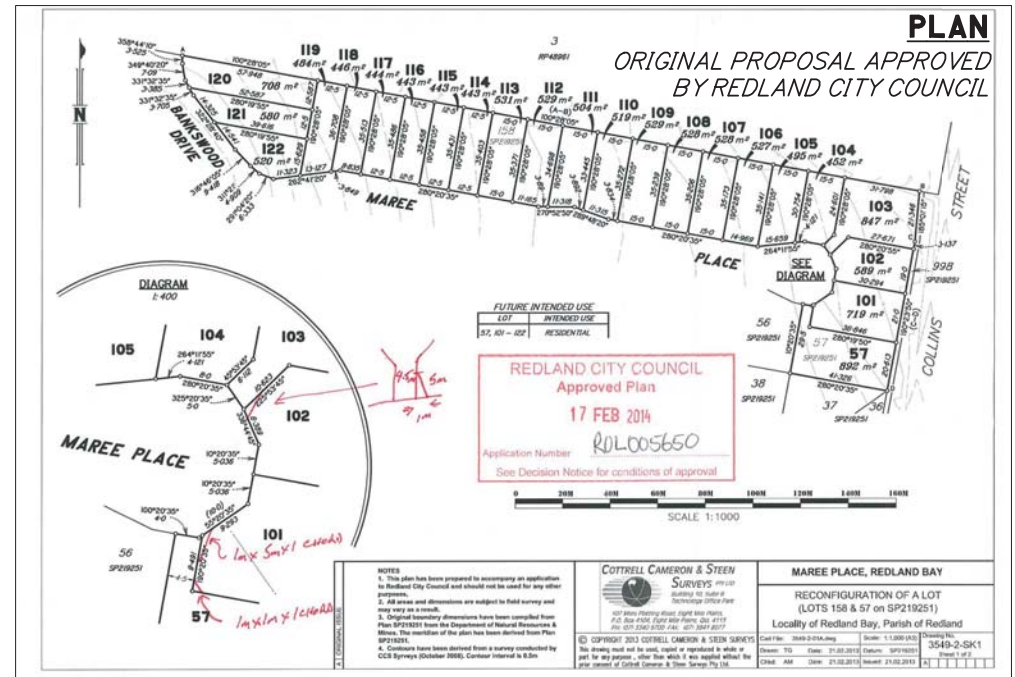

LEGEND

PROPOSED

- PROPOSED VEHICULAR CONCRETE PAVEMENT (REFER ADJACENT DETAILS)
- KERB ADAPTOR (REFER STD DWG R-ASC-7)

EXISTING

- SURFACE CONTOUR
- STORMWATER MANHOLE AND GULLY PIT
- WATER MAIN
- ELECTRICITY
- TELSTRA
- GAS
- KERB ADAPTOR
- KERB AND CHANNEL

A ORIGINAL ISSUE	NOTES	<p>COTTRELL CAMERON & STEEN SURVEYS PTY LTD Building 10, Suite B Technology Office Park 107 Miles Platting Road, Eight Mile Plains, P.O. Box 4104, Eight Mile Plains, Qld. 4113 PH: (07) 3340 9700 FAX: (07) 3841 8077</p> <p>© COPYRIGHT 2014 COTTRELL CAMERON & STEEN SURVEYS This drawing must not be used, copied or reproduced in whole or part for any purpose, other than which it was supplied without the prior consent of Cottrell Cameron & Steen Surveys Pty Ltd.</p>	DISCLOSURE PLAN	
	<p>Note: - This plan is prepared to comply with disclosure plan requirements of the Land Sales Act 1984 and is not to be used for any other purpose.</p>		<p>PROPOSED LOT 106 DESCRIBED AS PART OF LOT 158 ON SP219251</p>	
		<p>Cad File: 3549-2-01B-Disclosure Drawn: TG Date: 12.03.2014 Chkd: BC Date: 12.03.2014</p>	<p>Scale: NTS Datum: Issued: 12.03.2014</p>	

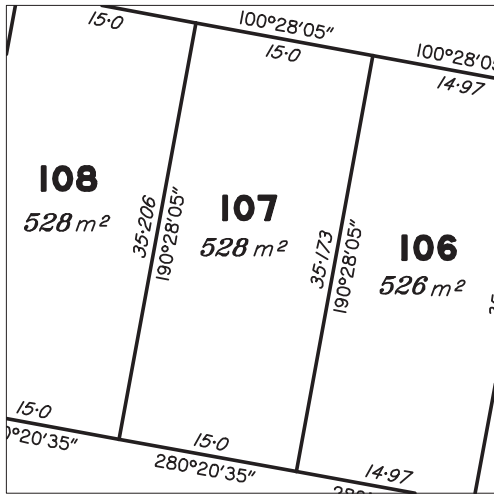
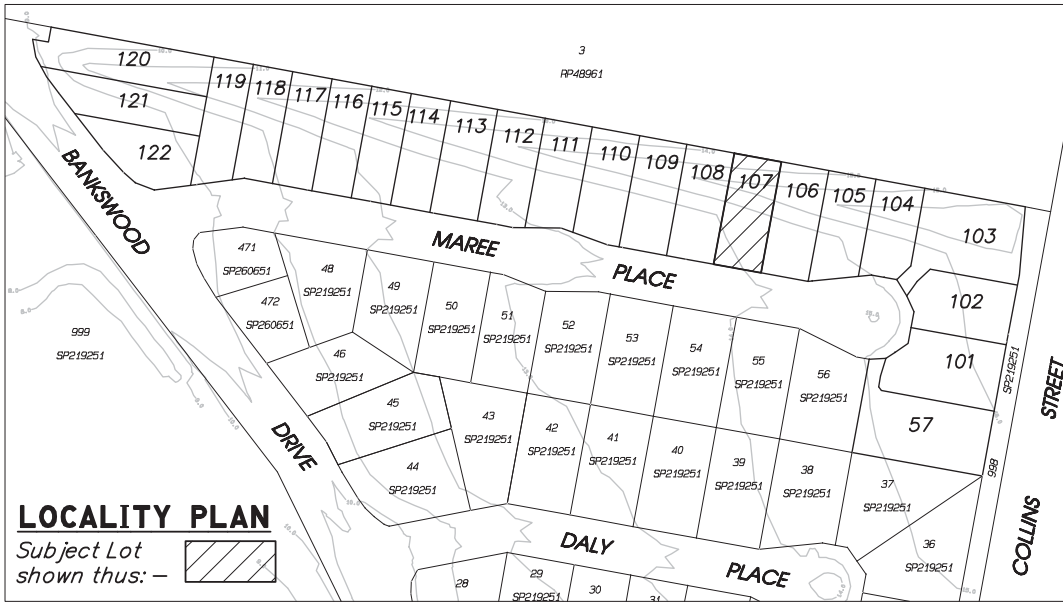

PLAN OF LOT
DESCRIBED AS BEING PART OF LOT 158 ON SP219251

Metes and Bounds description of the area of land being on the Plan of Proposed Lot Reconfiguration prepared by Cottrell Cameron & Steen Surveys Pty Ltd referred to as Drawing Number 3549-2-SK1 dated 21 February 2013 which was approved by Redland City Council on 17 February 2014, described as Lot 158 on SP219251, Parish of Redland, County of Stanley and situated at 41 Bankswood Drive, Redland Bay

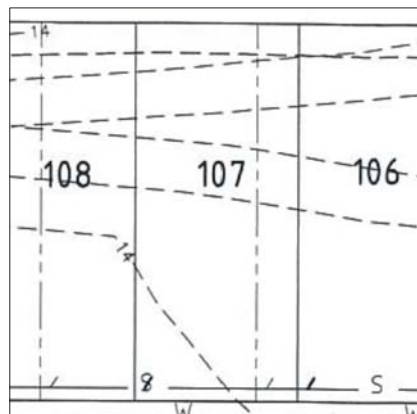
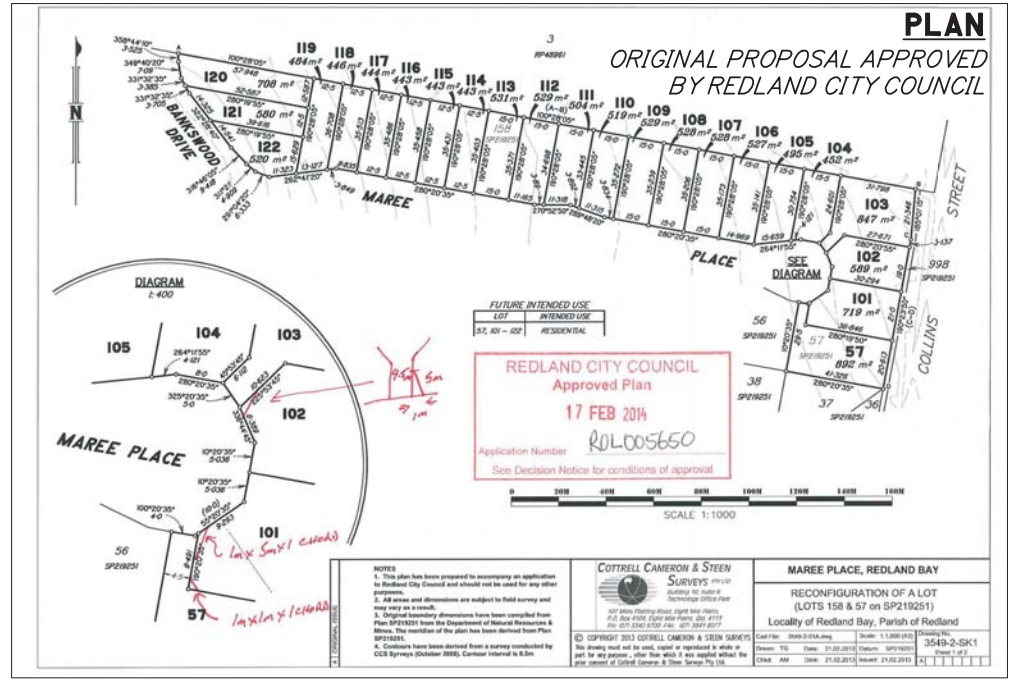

PLAN
ENGINEERING PROPOSAL

A ORIGINAL ISSUE		<p>107 Miles Platting Road, Eight Mile Plains, P.O. Box 4104, Eight Mile Plains, Qld. 4113 PH: (07) 3340 9700 FAX: (07) 3841 8077</p> <p>© COPYRIGHT 2014 COTTRELL CAMERON & STEEN SURVEYS This drawing must not be used, copied or reproduced in whole or part for any purpose, other than which it was supplied without the prior consent of Cottrell Cameron & Steen Surveys Pty Ltd.</p>	DISCLOSURE PLAN	
			PROPOSED LOT 107 DESCRIBED AS PART OF LOT 158 ON SP219251	
			Cad File: 3549-2-01B-Disclosure Drawn: TG Date: 12.03.2014 Chkd: BC Date: 12.03.2014	Scale: NTS Datum: Issued: 12.03.2014

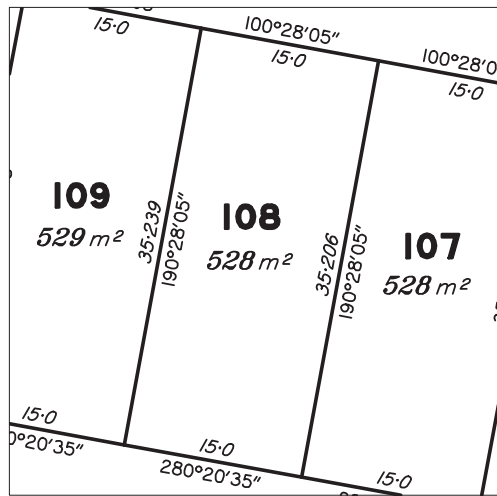
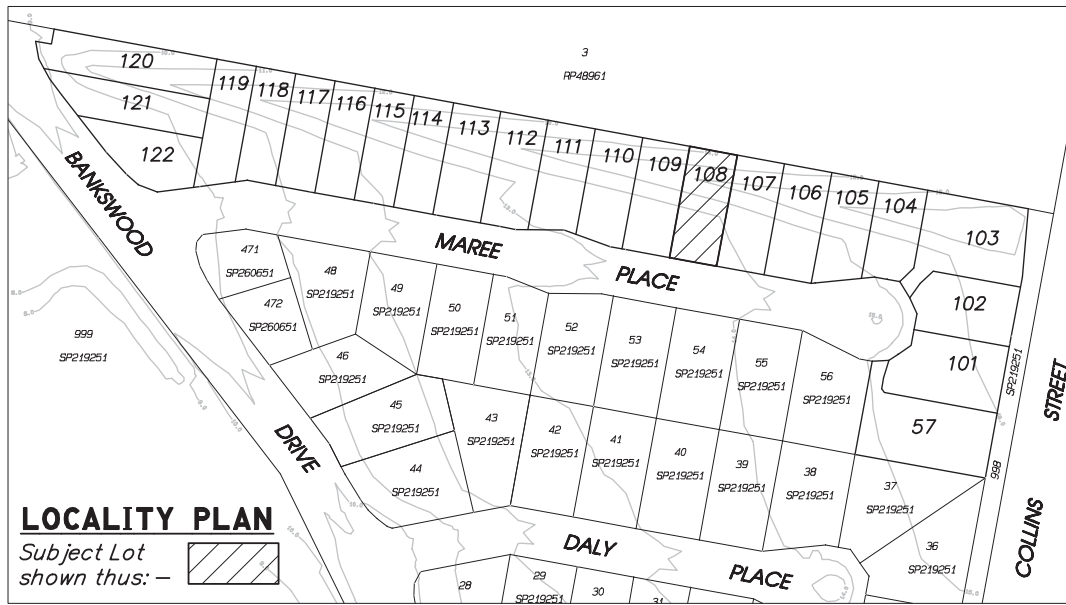

PLAN OF LOT
DESCRIBED AS BEING PART OF LOT 158 ON SP219251

Metes and Bounds description of the area of land being on the Plan of Proposed Lot Reconfiguration prepared by Cottrell Cameron & Steen Surveys Pty Ltd referred to as Drawing Number 3549-2-SK1 dated 21 February 2013 which was approved by Redland City Council on 17 February 2014, described as Lot 158 on SP219251, Parish of Redland, County of Stanley and situated at 41 Bankswood Drive, Redland Bay

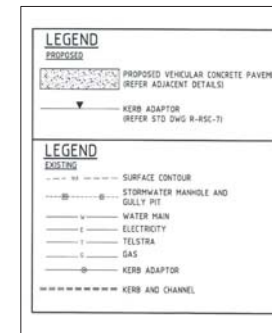
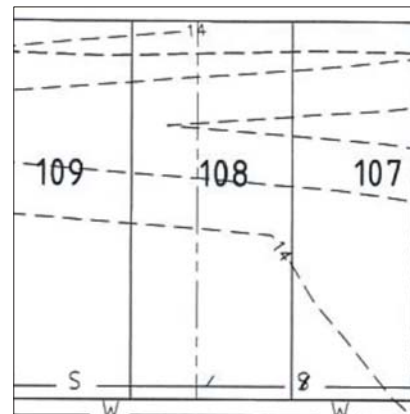
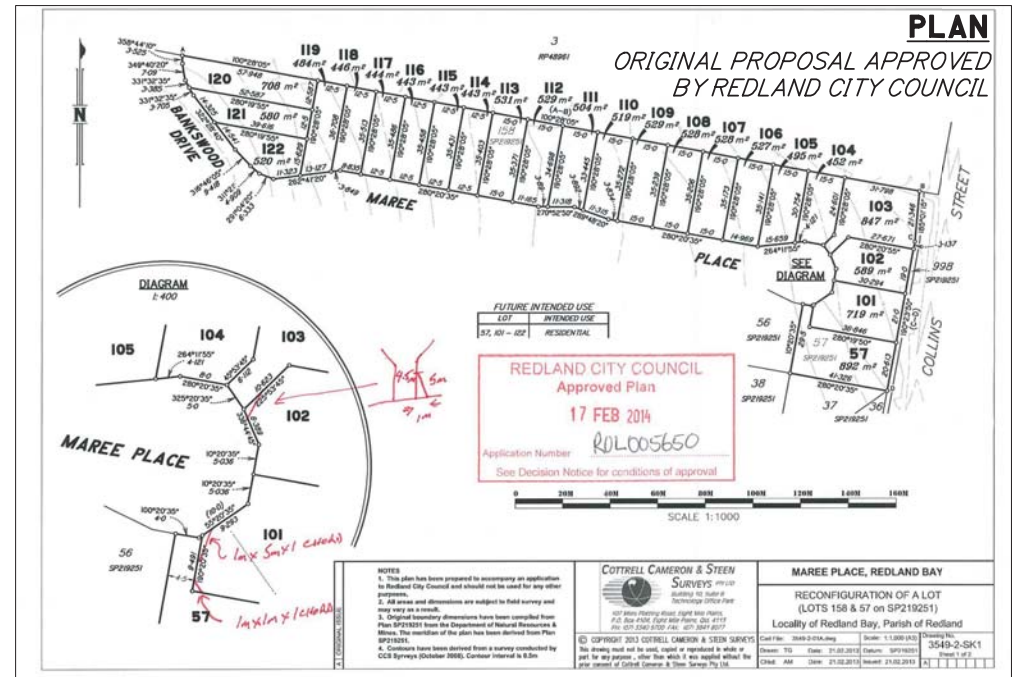

A ORIGINAL ISSUE

NOTES

Note: - This plan is prepared to comply with disclosure plan requirements of the Land Sales Act 1984 and is not to be used for any other purpose.

COTTRELL CAMERON & STEEN
SURVEYS PTY LTD
Building 10, Suite B
Technology Office Park
107 Miles Platting Road, Eight Mile Plains,
P.O. Box 4104, Eight Mile Plains, Qld. 4113
PH: (07) 3340 9700 FAX: (07) 3841 8077

© COPYRIGHT 2014 COTTRELL CAMERON & STEEN SURVEYS
This drawing must not be used, copied or reproduced in whole or part for any purpose, other than which it was supplied without the prior consent of Cottrell Cameron & Steen Surveys Pty Ltd.

DISCLOSURE PLAN

PROPOSED LOT 108 DESCRIBED AS PART OF LOT 158 ON SP219251

Cad File: 3549-2-01B-Disclosure	Scale: NTS	Drawing No. 3549-Lot 108
Drawn: TG	Date: 12.03.2014	Datum:
Chkd: BC	Date: 12.03.2014	Issued: 12.03.2014
		Sheet 1 of 1

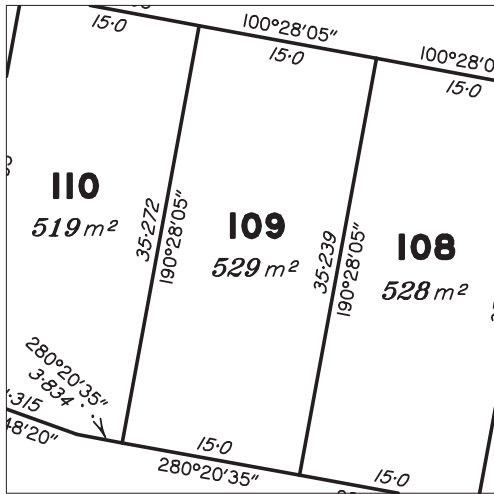
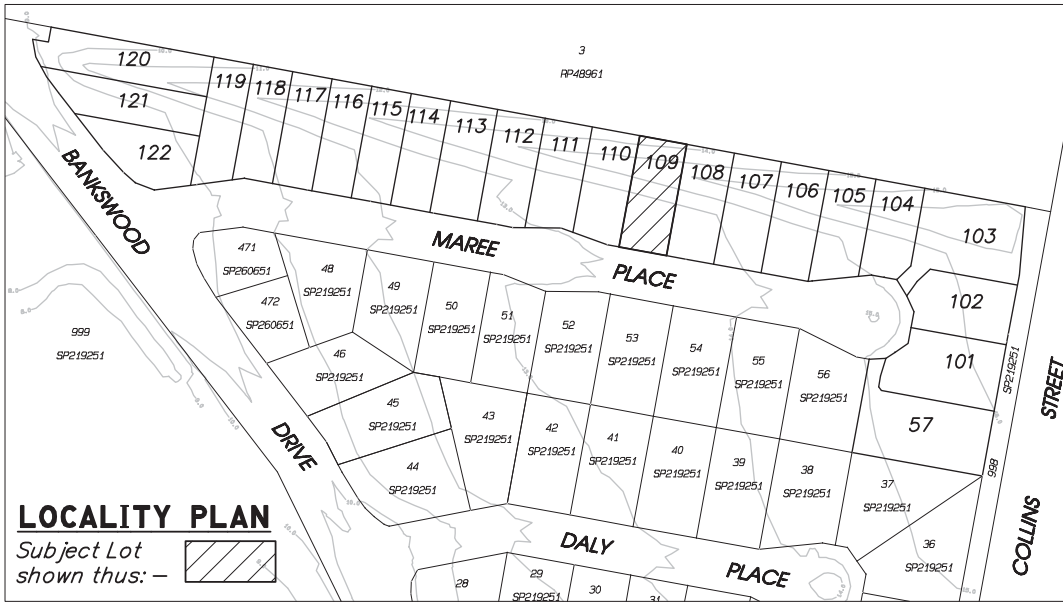

PLAN OF LOT
DESCRIBED AS BEING PART OF LOT 158 ON SP219251

Metes and Bounds description of the area of land being on the Plan of Proposed Lot Reconfiguration prepared by Cottrell Cameron & Steen Surveys Pty Ltd referred to as Drawing Number 3549-2-SK1 dated 21 February 2013 which was approved by Redland City Council on 17 February 2014, described as Lot 158 on SP219251, Parish of Redland, County of Stanley and situated at 41 Bankswood Drive, Redland Bay

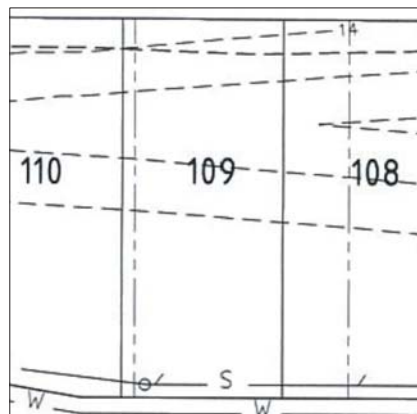
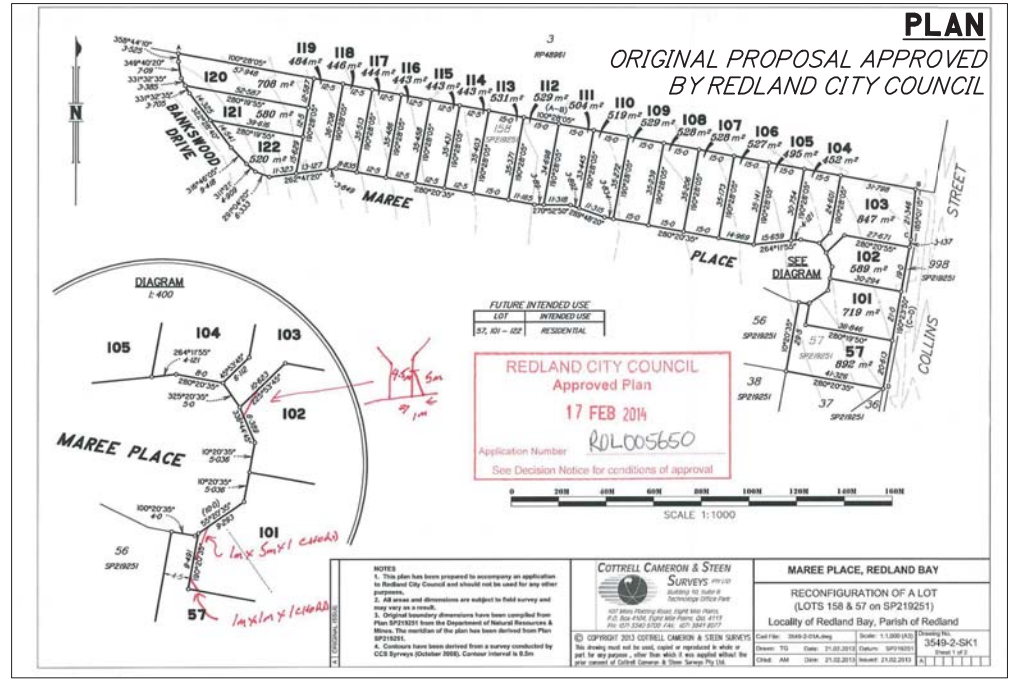

PLAN
ENGINEERING PROPOSAL

LEGEND	
	PROPOSED VEHICULAR CONCRETE PAVEMENT (REFER ADJACENT DETAILS)
	KERB ADAPTOR (REFER STD DWG R-ASC-7)
LEGEND	
	SURFACE CONTOUR
	STORMWATER MANHOLE AND GULLY PIT
	WATER MAIN
	ELECTRICITY
	TELSTRA
	GAS
	KERB ADAPTOR
	KERB AND CHANNEL

ORIGINAL ISSUE	NOTES	<p>COTTRELL CAMERON & STEEN SURVEYS PTY LTD Building 10, Suite B Technology Office Park 107 Miles Platting Road, Eight Mile Plains, P.O. Box 4104, Eight Mile Plains, Qld. 4113 PH: (07) 3340 9700 FAX: (07) 3841 8077</p> <p>© COPYRIGHT 2014 COTTRELL CAMERON & STEEN SURVEYS This drawing must not be used, copied or reproduced in whole or part for any purpose, other than which it was supplied without the prior consent of Cottrell Cameron & Steen Surveys Pty Ltd.</p>	DISCLOSURE PLAN									
			PROPOSED LOT 109 DESCRIBED AS PART OF LOT 158 ON SP219251									
			<table border="1"> <tr> <td>Cad File: 3549-2-01B-Disclosure</td> <td>Scale: NTS</td> <td>Drawing No: 3549-Lot 109</td> </tr> <tr> <td>Drawn: TG</td> <td>Date: 12.03.2014</td> <td>Datum:</td> </tr> <tr> <td>Chkd: BC</td> <td>Date: 12.03.2014</td> <td>Issued: 12.03.2014</td> </tr> </table>	Cad File: 3549-2-01B-Disclosure	Scale: NTS	Drawing No: 3549-Lot 109	Drawn: TG	Date: 12.03.2014	Datum:	Chkd: BC	Date: 12.03.2014	Issued: 12.03.2014
Cad File: 3549-2-01B-Disclosure	Scale: NTS	Drawing No: 3549-Lot 109										
Drawn: TG	Date: 12.03.2014	Datum:										
Chkd: BC	Date: 12.03.2014	Issued: 12.03.2014										
Sheet 1 of 1												

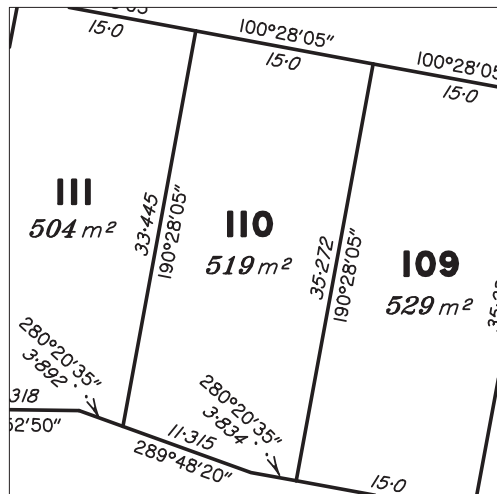
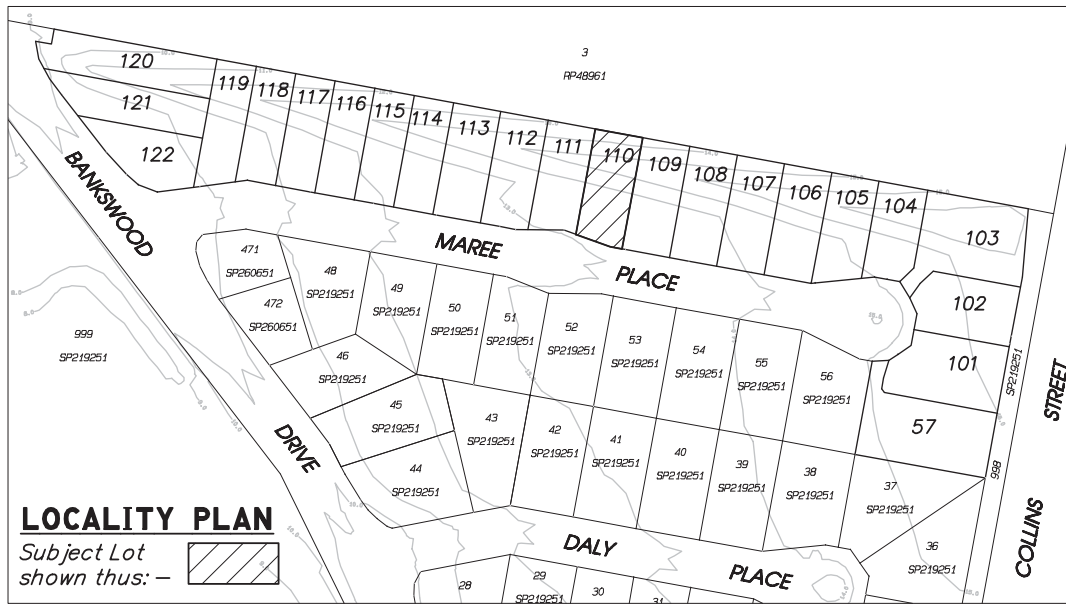

PLAN OF LOT

DESCRIBED AS BEING PART OF LOT 158 ON SP219251

Metes and Bounds description of the area of land being on the Plan of Proposed Lot Reconfiguration prepared by Cottrell Cameron & Steen Surveys Pty Ltd referred to as Drawing Number 3549-2-SK1 dated 21 February 2013 which was approved by Redland City Council on 17 February 2014, described as Lot 158 on SP219251, Parish of Redland, County of Stanley and situated at 41 Bankswood Drive, Redland Bay

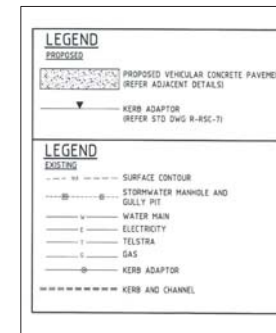
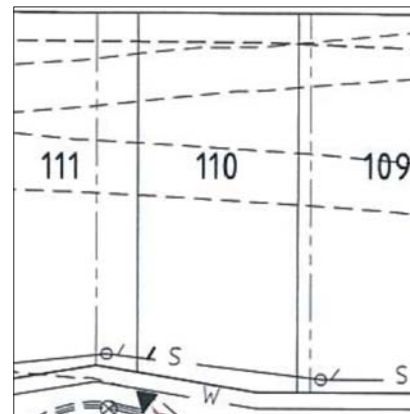
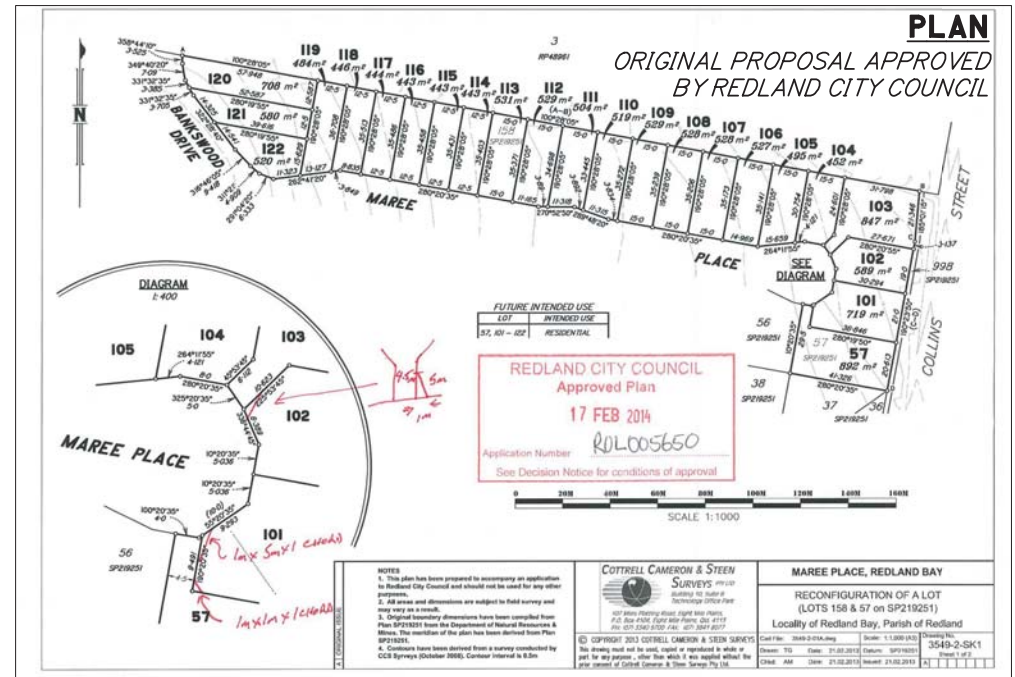

A. ORIGINAL ISSUE	NOTES	<p>COTTRELL CAMERON & STEEN SURVEYS PTY LTD Building 10, Suite B Technology Office Park 107 Miles Platting Road, Eight Mile Plains, P.O. Box 4104, Eight Mile Plains, Qld. 4113 PH: (07) 3340 9700 FAX: (07) 3841 8077</p> <p>© COPYRIGHT 2014 COTTRELL CAMERON & STEEN SURVEYS This drawing must not be used, copied or reproduced in whole or part for any purpose, other than which it was supplied without the prior consent of Cottrell Cameron & Steen Surveys Pty Ltd.</p>	DISCLOSURE PLAN																				
			PROPOSED LOT 110 DESCRIBED AS PART OF LOT 158 ON SP219251																				
			<table border="1"> <tr> <td>Cad File:</td> <td>3549-2-01B-Disclosure</td> <td>Scale:</td> <td>NTS</td> </tr> <tr> <td>Drawn:</td> <td>TG</td> <td>Date:</td> <td>12.03.2014</td> </tr> <tr> <td>Chkd:</td> <td>BC</td> <td>Date:</td> <td>12.03.2014</td> </tr> </table>	Cad File:	3549-2-01B-Disclosure	Scale:	NTS	Drawn:	TG	Date:	12.03.2014	Chkd:	BC	Date:	12.03.2014	<table border="1"> <tr> <td>Datum:</td> <td></td> </tr> <tr> <td>Issued:</td> <td>12.03.2014</td> </tr> </table>	Datum:		Issued:	12.03.2014	<table border="1"> <tr> <td>Drawing No.</td> <td>3549-Lot 110</td> </tr> <tr> <td>Sheet 1 of 1</td> <td></td> </tr> </table>	Drawing No.	3549-Lot 110
Cad File:	3549-2-01B-Disclosure	Scale:	NTS																				
Drawn:	TG	Date:	12.03.2014																				
Chkd:	BC	Date:	12.03.2014																				
Datum:																							
Issued:	12.03.2014																						
Drawing No.	3549-Lot 110																						
Sheet 1 of 1																							